



Prospects of Hybrid Electric Vehicles (HEVs) and Alternate Fuel Vehicles in India

V. G. Gujrathi
Tata Motors Limited
October 31, 2007



Outline

- Introduction to Tata Motors
- Future of Alternate Fuel vehicles and Hybrid Electric Vehicles
- Enabling Technologies for HEVs and EVs
- Initiatives in India for Sustainable Transportation
- Initiatives by Tata Motors in Alternate Fuels and Hybrid and Electric Vehicles



Outline

- Introduction to Tata Motors
- Future of Alternate Fuel vehicles and Hybrid Electric Vehicles
- Enabling Technologies for HEVs and EVs
- Initiatives in India for Sustainable Transportation
- Initiatives by Tata Motors in Alternate Fuels and Hybrid and Electric Vehicles



Tata Motors

- India's largest Automotive company in revenue terms
- Began manufacturing commercial vehicles in 1954
- World's fifth largest Commercial Vehicle Manufacturer
- India's second largest passenger car manufacturer
- Net Turnover of Rs. 324 Billion (US\$ 7.9 Billion) and net earnings of Rs. 22 Billion (US\$ 540 Million)
- Strong R&D skill sets
 - Capability to develop vehicle platforms indigenously at a relatively low cost
 - One of 94 High Leverage Innovators according to the annual Booz Allen Hamilton Survey of the world's 1000 largest R&D spenders
- Currently has four manufacturing plants at Jamshedpur, Pune, Lucknow and Gunsan (S. Korea)
- Widest range of product offerings in Indian market
 - Commercial vehicles, Multi-Utility vehicles and Passenger cars



Tata Motors Today - Operations



- JV with Fiat for manufacture of passenger cars in India
- JV with Marco Polo, Brazil, for manufacture of buses in India
- Assembly operations in Malaysia, Kenya, Bangladesh, Spain, Ukraine, Russia and Senegal.



Comprehensive Product Range

Trucks



Buses



Passenger Cars





Outline

- Introduction to Tata Motors
- **Future of Alternate Fuel vehicles and Hybrid Electric Vehicles**
- Enabling Technologies for HEVs and EVs
- Initiatives in India for Sustainable Transportation
- Initiatives by Tata Motors in Alternate Fuels and Hybrid and Electric Vehicles



Changing Scenario in Automobiles in India/World

- **Environmental Challenges**
 - Dwindling of Petroleum Reserves
 - Global Warming
- **Societal Challenges**
 - Increasing urban pollution
 - Rising cost of fuel
- **Market Challenges**
 - Increasing customer preferences for “Clean” technologies
 - Highly competitive domestic market – need for (radical) product differentiation
- **Regulatory Requirements**
 - Tighter governmental regulations on emissions, safety etc.
 - Pace of introduction of new regulations faster than in the past

Days of Single Fuel Vehicles are gone



Alternate Fuel/Propulsion Options

- Conventionally, only single fuel vehicles – Gasoline, Diesel
- Alternate fuel option of CNG/LPG
- Fuel blends and hybridisation offer two different directions to powertrain selection
 - Percentage of blend (5%, 20%, 30% etc.) leading up to fully alternate fuels (100% blend)
 - Amount of hybridisation (micro, mild, full, etc.) leading up to electric vehicles (100% hybridisation) and fuelcell vehicles



Powertrain Options Matrix

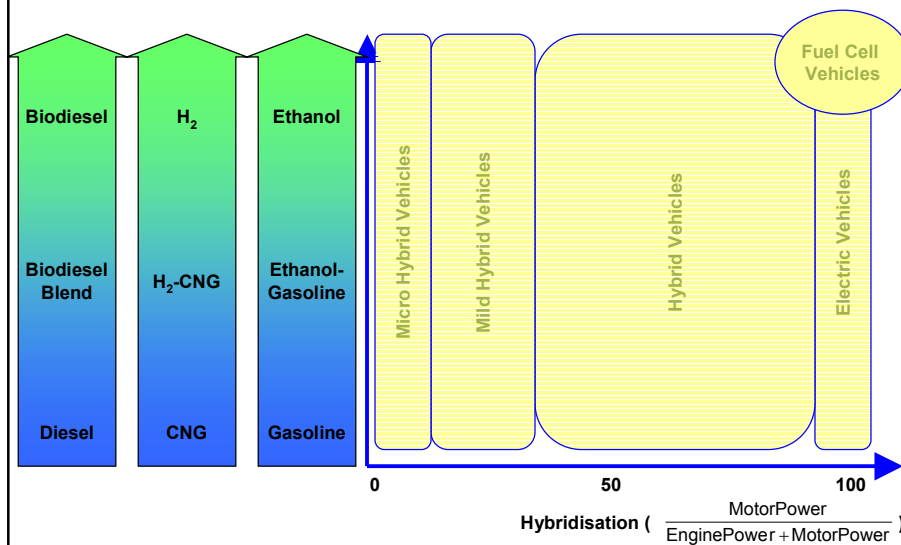

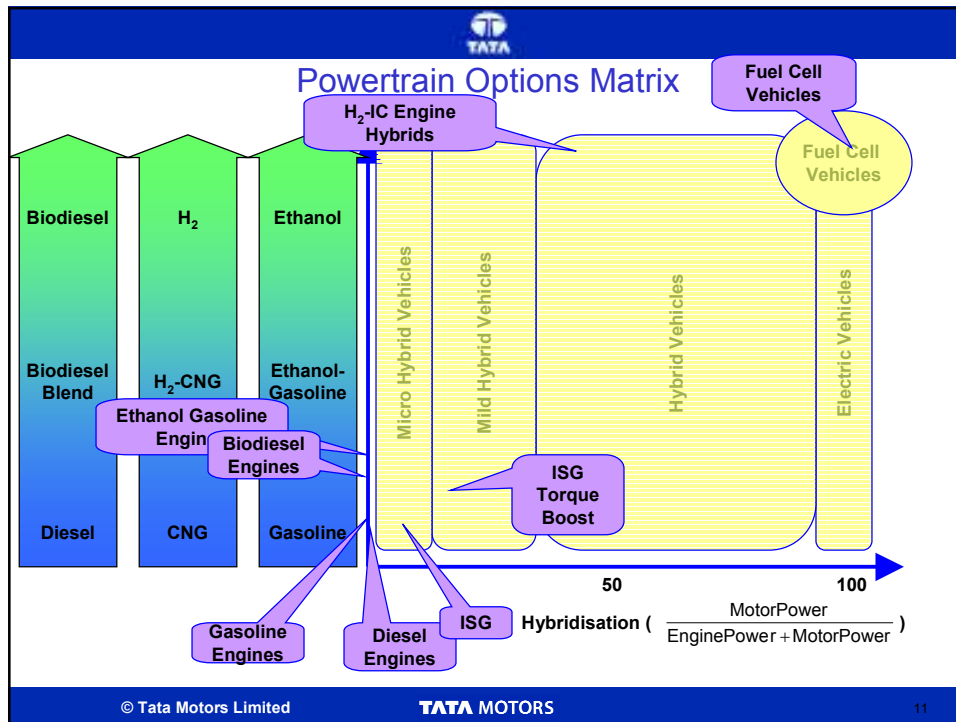

Choosing from the Powertrain Matrix

- Ideally, there is a finite market for vehicle products belonging to any category in the powertrain matrix – the question is how big.
- Sustainable solutions result from those products which satisfy the needs of a sizeable number of people
- Constraints for technology options to be economically viable:
 - Along "Blend" axis
 - Availability of fuel (Ethanol, Bio-diesel, H₂ etc.)
 - Infrastructure (storage and transport of H₂)
 - Along "Hybridisation" axis
 - Acquisition costs of electrical power components (motors, controllers, batteries, etc.)
 - Control strategies for harmonising mechanical and electrical systems
 - Torque addition in parallel hybrid systems
 - Maintaining state-of-charge of storage systems in series/parallel/series-parallel systems

© Tata Motors Limited TATA MOTORS 12



Choosing from the Powertrain Matrix

- Product success depends on
 - Incremental acquisition cost compared to baseline conventional vehicle
 - Running costs (costs of alternate fuels, savings from improved efficiency through hybridisation)
 - Replacement costs (replacements of battery packs)
 - Added value
 - Better driveability (through hybridisation)
 - Reduction in NVH (silent operation of EVs and fuel cell vehicles, silent start using ISG)
 - Less pollution / Better environmental compliance (lower smoke levels for Biodiesel engines, lower NO_x for H₂-CNG engines)
 - Minimising negative value
 - Safety issues (high voltage and current in hybrid vehicles, hydrogen safety issues in H₂ IC engines and fuel cells)
 - Any adjustment required in driver behaviour to get the best out of the new technology (driver skill required to maximise brake energy capture through regeneration in hybrid vehicles)
 - More components – more reliability issues
 - Material compatibility issues (corrosion due to ethanol/biodiesel, special material requirements for hydrogen handling)
 - Difficulty for customer to get the fuel (H₂ availability, EV charging time)
 - Conversion efficiency – energy required to produce the fuel



Current Challenges and Opportunities for EVs and HEVs

- Current battery technology limitations
 - Limited energy density
 - Poor power to weight ratio
 - High charging time
 - Limited charge / recharge cycles and hence limited life
 - High acquisition & replacement cost
 - Safety, handling, and recyclability
- New battery technologies like Li-Ion are improving the situation, but are not mature yet
- Costs of electric power train components – motors, drives, dc-dc converters
- Reduction in weight of EV (to improve range and performance) a major challenge
- Availability of charging facilities poses an infrastructure issue for EVs and plug-in hybrids

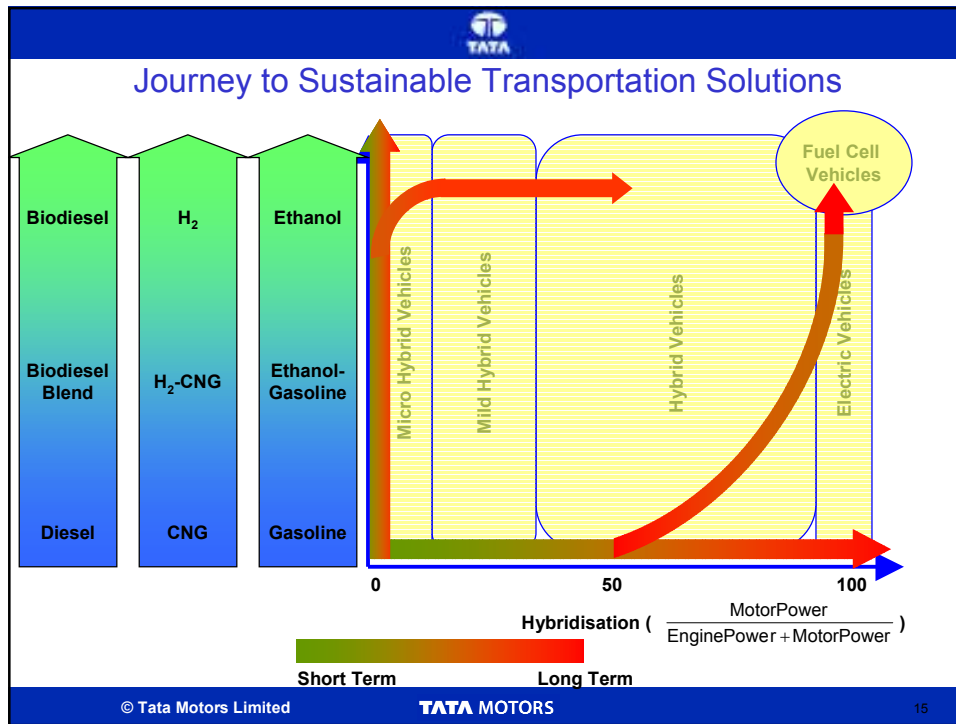

TATA

Integrated Starter Generator with Auto Stop-Start

- Combines the starter motor and alternator in a vehicle into one component
- Stops the engine as soon as the vehicle comes to a stop – no idling
- 8 – 12 % improvement in fuel economy
- Reduce pollution in high traffic areas
- Faster, quieter starting compared to conventional starter motors
- Regenerative energy capture could further improve fuel economy

Engine ISG Battery

Starting – Battery drives the ISG to start the engine

Engine ISG Battery

Running – Engine charges the battery through ISG

© Tata Motors Limited **TATA MOTORS** 16



Series Hybrid

- Suitable for intra-city traffic with frequent starts and stop
- Common electric traction system for a variety of power sources
- Fixed speed reduction possible – no gear-shifts, clutch operation
- Fuel economy more or less independent of driving conditions and driving habits
- Zero-emission operation possible

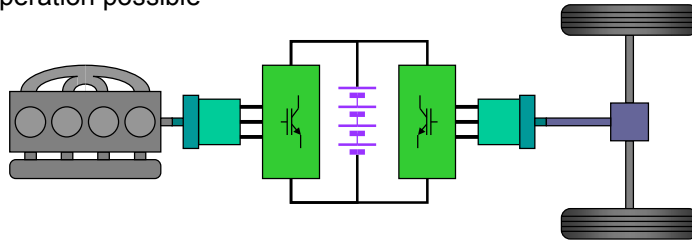

Parallel Hybrid

- Suitable for inter-city long-distance buses with limited city running
- Smaller electric motor and controller rating
- Easier adaptation on existing powertrain
- Fuel economy varies with driving conditions and driving habits – difficult to optimise control strategy
- Limited zero-emission capability (with reduced performance)

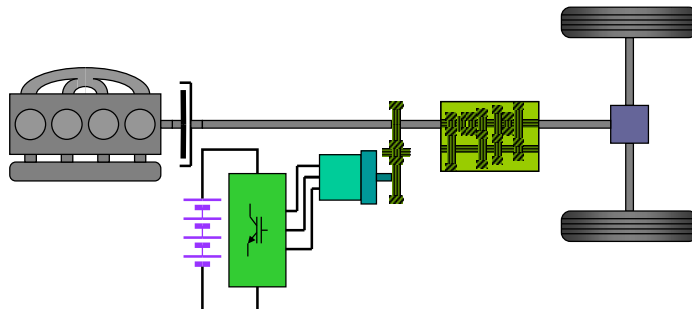



Parallel Hybrid with Road Coupling

- Electric motors drive rear wheels
- All features of parallel hybrid
- Easier packaging
- Four wheel drive capability
- Good regeneration capability

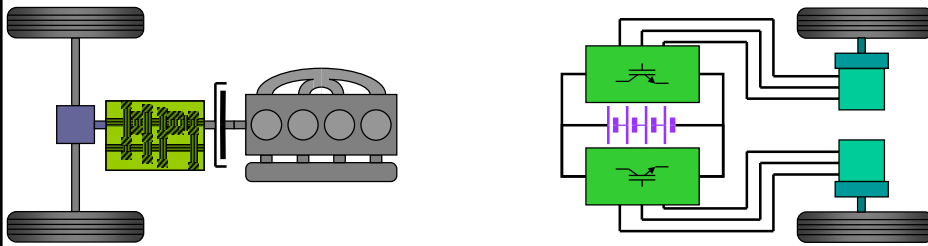

Series-Parallel Hybrid

- Two alternate power paths
- Engine-transmission-wheels
- Engine-generator-(battery)-motor-wheels
- Better flexibility in powertrain control
- Better fuel economy than series or parallel configurations
- More electrical/power electronic components
- More complex control strategies

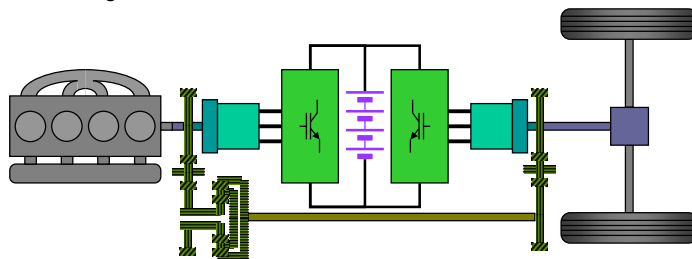



Plug-in Hybrid

- Suitable for cities with well developed electrical infrastructure
- Zero-emission operation possible
- All benefits of EV without the restriction of range – could have smaller batteries than EV

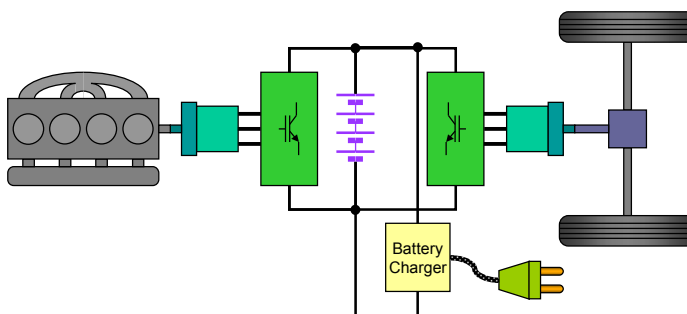

Hybrid Vehicle Configurations

Most suitable configuration depends on specifications, market segment, drive cycle, fuel economy, emission reductions, packaging constraints, ownership cost, return on investment, value perceived by customer.

Table gives in general preferred configurations for each application :

Vehicle Type	Application	Suitable HEV Configuration	Remarks
Car	Personal	Start-Stop / Parallel / Series / Series-Parallel	Series-parallel is best for a mix of intra city and highway driving.
	Intra City Taxi	Start-Stop / Parallel / Series / Series-Parallel	Start-Stop / Mild Parallel hybrid is best for bumper to bumper city traffic.
	Inter City Taxi	Mild Parallel	Vehicles with mixed cycle (Urban + Highway). Hybrids are not suitable for pure Highway cycles.
SUV	SUV	Parallel	This provides high torque for off-road applications
LCV's	Passenger – Intra City	Series	Better for bumper to bumper city traffic.
	Passenger – Inter City	Mild Parallel	Vehicles with mixed cycle (Urban + Highway).
	Cargo – Intra City	Series	Better for bumper to bumper city traffic.
	Cargo – Inter City	Mild Parallel	Vehicles with mixed cycle (Urban + Highway).
MCV / HCV's	Passenger – Intra City	Series	Better for bumper to bumper city traffic.
	Passenger – Inter City	Mild Parallel	Vehicles with mixed cycle (Urban + Highway).
	Cargo – Inter City	Mild Parallel	Vehicles with mixed cycle (Urban + Highway).



Outline

- Introduction to Tata Motors
- Future of Alternate Fuel vehicles and Hybrid Electric Vehicles
- **Enabling Technologies for HEVs and EVs**
- Initiatives in India for Sustainable Transportation
- Initiatives by Tata Motors in Alternate Fuels and Hybrid and Electric Vehicles



Battery Technology

- Batteries significantly affect the performance of electric vehicles (range, performance), and, to a lesser extent, of hybrid vehicles
- Main considerations in choosing a battery technology
 - For EVs
 - Energy density – Wh/kg, Wh/litre
 - Cost per kWh
 - Power density – W/kg, W/litre – affects vehicle performance and also fast-charging capability
 - Life
 - Safety, handling and recyclability
 - For HEVs
 - Power density - kW/kg, kW/litre – affects vehicle performance
 - Cost per kWh
 - Charge/discharge efficiency – affects fuel economy
 - Life
 - Safety, handling and recyclability



Battery Technology Options Today

- Lead Acid
 - Proven, established and reliable technology
 - Low energy density and power density
 - Low cost of manufacturing
 - Short cycle life
 - Lead is hazardous material; however, recycling procedures of lead-acid batteries are known and well-established
 - Major suppliers include Delphi, Exide, Amara Raja, etc.
- Nickel Cadmium
 - Medium energy density
 - Good power density
 - Long cycle life
 - Cadmium recycling is a serious issue
 - Major suppliers include SAFT
- Nickel Metal Hydride
 - Reasonable manufacturing volumes achieved for NiMH batteries for consumer electronics, and also for hybrid vehicles (Toyota Prius, Honda Civic Hybrid, etc.)
 - Good energy density and power density
 - Poor charge retention
 - Long cycle life
 - No major issues with hazardous materials
 - Major suppliers for HEV applications include Panasonic, Cobasys, Ovonic, SAFT, etc.



Battery Technology Options Today – contd.

- Sodium Nickel Chloride (Zebra batteries)
 - Proven battery technology
 - Very good energy density
 - Poor power density – comparable to Lead-acid batteries
 - Relatively less expensive than NiMH batteries
 - Long cycle life
 - High temperature operation (250 – 300 °C)
 - Major suppliers – Zebra (MES-DEA)
- Lithium Ion – Li-Thionyl Chloride, Li-Iron Phosphate, Li-Manganese Oxide
 - Emerging but commercially ready battery technology, being applied to many forthcoming EVs/HEVs (Mitsubishi IEV, GM Volt, etc.)
 - Very good energy density and power density
 - Similar cost as NiMH batteries – potential to be cheaper
 - Long cycle life
 - Safety concerns in terms of being prone to catching fire if abused (not all battery chemistries)
 - Major suppliers – SAFT, ElectroVaya, A123 Systems, Gaia, Altair Nanotechnologies, Axion





Ultracapacitors

- High power density
- Low energy density
- Up to 98% cyclic efficiency
- Long cycle life
- Suitable for regenerative energy capture



Battery Technology Comparison

Technology	Mfg cost	Cycle life at 80% DOD	Energy Density	Power Density	Charge efficiency	Remarks
	Rs./kWh		Wh/kg	W/kg	%	
Lead Acid	3,500	>200	35	150	70 – 92	•Cycle life •Use of lead
Ni-Cd	19,000	1500	55	500 – 1000	70 – 90	•Use of Cd
Ni-MH	35,000	1000	65 – 80	500 – 1000	66	•Cost
Na-NiCl ₂	10,000 – 15,000	1000	90 – 100	150	NA	•High temp. operation
Li-Ion	17,500 – 35,000	1000	150 – 200	1000+	99.9	•Safety



Comparison of Traction Motor Drive Technology for Vehicle Applications

Parameter	Technology			
	Wound Field DC Motor	AC Induction Motor	Permanent Magnet Synchronous Motor	Switch Reluctance Motor
Rotor Construction	Laminated rotor Armature windings Split rings Carbon brushes	Laminated rotor Aluminum bars for field windings No split/slip rings No brushes	Laminated/solid rotor Embedded Permanent magnets No split/slip rings No brushes	Laminated/solid rotor No Permanent magnets No split/slip rings No brushes
Stator construction	Laminated/Solid Stator Field windings DC +ve and -ve terminals	Laminated Stator Three-phase armature windings Three-phase terminals	Laminated Stator Three-phase armature windings Three-phase terminals	Laminated Stator Four-phase armature windings Four-phase terminals
Controller	Half Bridge Converter with two IGBTs Additional low power full bridge converter for field control	Three-phase controller with Six IGBTs	Three-phase controller with Six IGBTs	Four-phase controller with Eight IGBTs
Controller Algorithm	Simple current/voltage control	Vector control Direct Torque control	Vector control Direct Torque control	Multi-phase excitation
Machine Efficiency	75%	90%	92%	90%
Constant power operation	> 5 times rated speed	4 - 5 times rated speed	2 - 3 times rated speed	>5 times rated speed
Rotor losses	High	Moderate	Low	Moderate
Stator losses	Low	Moderate	Moderate	Moderate
Water cooling	Less effective	Quite effective	Very effective	Quite effective
High temperature operability	Good	Very good	Moderate (Permanent magnets)	Very good
Net Power density	Low	Moderate-High	High	High
Cost of machine	High	Low	High	Low
Cost of controller	Low	Moderate	Moderate	High
Maturity for Traction application	Mature/Obsolete	Mature	Mature	In development



Motor Drive Technology – Emerging Solutions

- High power, compact electric liquid cooled motor designs are possible with the help of highly evolved finite element analysis techniques
- Falling semiconductor prices offer cost-effective traction drive solutions based on induction machines and permanent magnet machines
- Emerging technologies for traction motors
 - Switched reluctance motors
 - Axial flux motors
 - Hub-mounted permanent magnet motors



Outline

- Introduction to Tata Motors
- Future of Alternate Fuel vehicles and Hybrid Electric Vehicles
- Enabling Technologies for HEVs and EVs
- **Initiatives in India for Sustainable Transportation**
- Initiatives by Tata Motors in Alternate Fuels and Hybrid and Electric Vehicles



Current Initiatives by Government of India in Alternate Fuels and Alternate Propulsion Systems

- President's Vision for 2020:
"India would have realized energy security and will be working towards energy independence"
- In 2002, a Supreme Court ruling resulted in the entire City Bus fleet of Delhi converted to CNG
- Euro 3 norms implemented in major cities; Euro 2 in rest of India; lag in implementation of air quality norms vis-à-vis Europe is being reduced
- State of Karnataka has waived Sales tax and Road tax for electric vehicles
- Mandatory blending of 5 – 10% ethanol in gasoline underway across the country
- Govt. of India has established National Bio-Diesel Mission to have an enterprise-driven bio-diesel production in the country
- Several industry and cooperative organisations actively engaged in cultivation of bio-diesel crops, as well as production and distribution of bio-diesel fuel



Current Initiatives by Government of India in Alternate Fuels and Alternate Propulsion Systems

- National technology initiatives for developing alternate fuel and alternate propulsion technologies under Technology Information Forecasting & Assessment Council (TIFAC), under DoST
- National Hydrogen Energy Board has announced an investment of Rs. 250 Billion (US\$ 6 Billion) during 2006-2020 for setting up a hydrogen infrastructure and for research and development in Hydrogen technology



Outline

- Introduction to Tata Motors
- Future of Alternate Fuel vehicles and Hybrid Electric Vehicles
- Enabling Technologies for HEVs and EVs
- Initiatives in India for Sustainable Transportation
- Initiatives by Tata Motors in Alternate Fuels and Hybrid and Electric Vehicles



Alternate Fuels (Blend Axis)



Use Of H₂ (Up To 30%) In CNG As Fuel For LCV 407 BSII



- Product Deliverables
 - Demonstration of Hydrogen + CNG (up to 30%) Fueled Engine for LCV 407.
- Application
 - LCV 407

Features

- Hydrogen Fueled CNG Engine.
- Reduced NOx emissions.
- Better fuel economy.
- Very low emissions.



Use of Ethanol-Gasoline Blend in Tata Vehicles



- Product Deliverables
Ethanol blend Compliant vehicle
- Application
Indica MPFI and Indica family vehicles.

Features

- Trials with 7% & 10% ethanol mixed petrol without modification to engine & EMS
- Anti-corrosive additives are being added in the fuel.



Bio-Diesel Validation



- Product Deliverables
 - Bio-diesel blend compliant vehicle.
- Application
 - Initially Indica, LCV 709, LP1510 buses. Can be extended for other diesel vehicles.

Features

- Trials with 5 to 20 % bio-diesel blend without engine modification.
- Eco-friendly vehicle.



697 Hydrogen Fueled IC Engine. H₂-ICE



- Product Deliverables
 - Demonstration of 697 Hydrogen Fueled Engine for LP 1510 Bus.
- Application
 - LPO 1510

Features

- Hydrogen Fuelled Engine.
- Manifold Injection of Hydrogen
- Indigenous Combustion Modeling for ECU developed by IIT-M
- Zero Emission, Non Polluting Vehicle.



Use Of H₂ (Up To 30%) In CNG As Fuel For Indica Car



- Product Deliverables
 - Demonstration of Hydrogen + CNG (up to 30%) Fueled Engine for Indica car
- Application
 - Indica Car

Features

- Hydrogen Fuelled CNG Engine.
- Reduced NOx emissions.
- Better fuel economy.
- Very low emissions.

Alternate Propulsion Systems (Hybridisation Axis)

Electric Traction System for Buses



- Product Deliverables

- Electrical Traction System for application on Electric Hybrid / Trolley / Fuel Cell Buses with
 - BLDC motor – 1512 chassis for proof of concept
 - AC induction motors – High Capacity Bus

- Application

- City Bus
- Urban mass transport systems

Features

- Common drive technology using energy from any one of the following:
 - Overhead electric supply
 - Diesel/CNG genset
 - Fuelcell
- Zero emission traction solution (for trolley and Fuelcell buses)



Fuel cell based City Bus



▪ Product Deliverables

- Travel range between Fuel refilling – 250 km
- Drivability performance better than current city buses
- Zero emission
- Firming up vehicle design / packaging for later commercialization

▪ Application

- High capacity city buses and Inter city buses initially and later for SUVs and cars

Features

- On-Board compressed hydrogen storage
- Fuel cell powered
- Uses Electric Traction System being developed in Electric Traction System Project



Series Hybrid Vehicle on LCV Bus Platform



• Product Deliverables

- Series Hybrid electric vehicle based on LCV Bus (SFC407/LP709)
- BS-4 emission target

• Application

- LCV Buses

Features

- Energy efficient hybrid architecture optimised for stop-go traffic



Electric Vehicle based on Ace Platform



- Product Deliverables
 - Production ready prototype of Electric Vehicles based on Ace platform.
- Application
 - Ace Platform

Features

- Simple Electric Vehicle architecture for neighbourhood electric vehicle market in USA/Europe



Integrated Starter Generator



- Product Deliverables
 - Integrated Starter Generator (ISG) – 14 Volts for Indica petrol vehicle
 - Fuel economy improvement better than 8 %
- Application
 - Indica

Features

- Belt-driven Integrated Starter Generator with automatic stop-start and regeneration
- Higher electrical power capability than conventional alternator
- Reduction in components – conventional starter motor and ring gear



Hybrid Electric Car



■ Product Deliverables

- Validated Petrol-Electric Hybrid Vehicle drive train
- Fuel economy near comparable industry levels for Hybrid Electric - 20 km / lit. for Indica
- BS-3/BS-4 emissions

■ Application

- Indica and variants
- Possible adaptation of concept to other vehicle platforms in future

Features

- Series / Parallel Hybrid Electric Power-train
 - 2 cylinder Petrol engine
 - Brushless DC motor
 - Regenerative braking
 - Automatic clutch operation
- Quantum improvement in fuel economy
- Reduced emissions



Electric Vehicle based on Indica Platform



• Product Deliverables

- Five Prototype Electric vehicles will be produced on Indica platform.

• Application

- Indica Platform

Features

- Use of Li-Ion batteries for high energy and power density
- 200 km range



Way Forward

- Short Term (< 3 years)
 - Blend fuels for IC engine vehicles
 - Dual-fuel vehicles
 - Micro and Mild hybrid vehicles
- Medium Term (3 – 8 years)
 - Dual- and Tetra-fuel vehicles
 - Hybrid vehicles
 - Range-Extender Electric Vehicles for city cars
 - EVs for neighbourhood electric vehicles, delivery vehicles (last-mile transport)
 - Bio-fuel based vehicles
 - Trolley buses for intra-city mass transportation
- Long term solutions (> 8 years)
 - Electric vehicles for city cars, delivery vehicles (last-mile transport), LCV public transportation (Vans, taxis, etc.)
 - Hydrogen based vehicles (fuelcell and H₂ ICE) for inter-city and intra-city buses



Thank You